

PROTECO™ SHEET

Installation Procedure



2'10" char height,
21.2 m² total and
0.03 m²/s peak
smoke release of
PROTECO-SHEET
per UL1685 for
specific cable
designs



PROTECO™ SHEET
acquired
UL Verified Mark
as the fire spread
prevention
products of cable.

- Preparation -

Before using, confirm the contents as below.



① Measure the dimension of the bunched cables **(+100mm)** or the cable trays, and measure the sheet for the cutting dimension.

*Cutting dimension X = L (Covering size) + 100[mm]

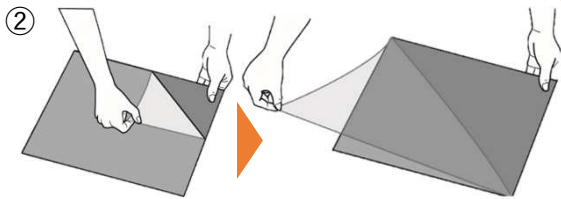

Remove the film.

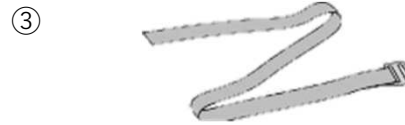

③ Confirm it whether Length of belts is **200[mm]** longer than the total wrapping length of the cables.

- Installation -

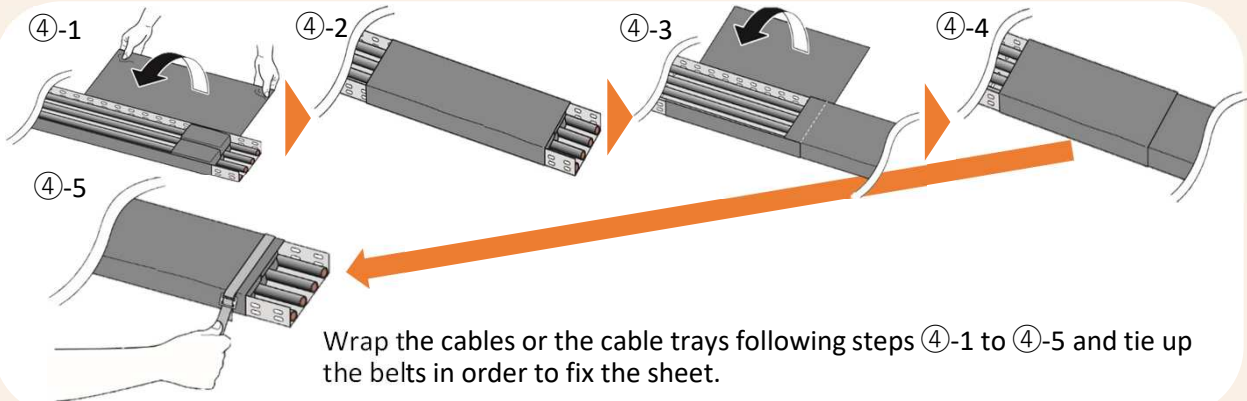

Wrap the cables or the cable trays following steps ④-1 to ④-5 and tie up the belts in order to fix the sheet.

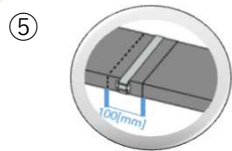

⑤ Overlap the sheet until on the other side of the sheet for **more than 100[mm]** to prevent water entry. The wrapping must be started from the bottom side to the upper side as shown in the circled figure.

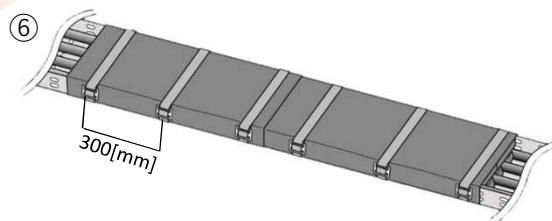

⑥ Tighten the belts in **every 300[mm]** length as shown in the figure. Also tighten the belts where the sheets are overlapped. Repeat these steps until all cables are completely wrapped.



PROTECO™ SHEET
promotion movie

Caution : If interspaces are formed between the cable and the sheet at the start and end portion, fill the fire retardant sealing material such the rock-wool-board or Firestop Block to eliminate the interspaces.